

# ProFoam 192 Power Cart Treatment System

The **Power Cart** provides a No Hand Pumping Required solution when applying Liquids - Dry Foam and Wet Foam applications. Using the 50' Foot Yellow Air Line expands the service treatment area out to a 100' radius, creating a service Treatment Zone unmatched by any other equipment. The **Power Cart** and expanded Treatment Zone provides the Operating Technician a consistent delivery output from the equipment the freedom to move through the service area applying precise amounts of chemical.

The **Power Cart** is quiet, easy to use and designed for various uses:  
*Drains - Small Fly, Ants, Termites just to name a few.*



Leans Back - Easy Access

Connects Quickly

High Performance Compressor

## System Contents

- ProFoam 192 1.5 Gallon Tank Dry Foam, Wet Foam and Liquid Outputs
- Power Cart Telescoping Handle with 120 Volt Compressor
- Trigger Gun c/w 60 Inch Connection Hose & Brass Quick Disconnecter
- 39 to 20 Inch Adjustable Extension Wand
- 3 Foam Tips, High Volume .25 Nylon, Stainless Steel .125 Flex Injection Tip, Fan Spray Tip
- 2 Liquid Tips, Pin and Cone, Fan Spray and Screen & Check Valve Filter
- 8 Foot Foam Output Extension Hose
- 1 Drain Plate: 5 Inch Aluminum Plate



\* New Model

\* Old Model

## Component Overview



### Tank Features

- The ProFoam 192 Tank is made of a durable high density, translucent, see through plastic.
- Durable heavy duty brass quick disconnects allow an easy transition between Dry Foam, Wet Foam or Liquid Applications
- No adjustments are necessary to achieve the correct expansion or delivery of foam applications.
- No internal parts, thereby avoiding constant repair problems associated with check and adjusting valves found in old equipment design.



### Measuring Scale

Chemical costs and government regulations now make exact measurement a must. The ProFoam 192 translucent tank and Measuring Scale makes it easy to accurately record chemical usage. The amount of liquid chemical and or foam applied at each job location is very small and impossible to accurately guesstimate when using solid stainless steel or aluminum sprayers.

### Hand Pump or Pressurized

ProFoam 192 comes standard with growth potential so you can add on additional options at a later date. By example, the Air Inlet Connector mounted on the tank allows the system to be pressurized by an air compressor



### Hand Pump

The air shaft of the ProFoam 192 is large and allows minimal pumping (30 Times) to reach an adequate pressure level. The Hand Pump is priced economically, allowing for complete pump replacement when the parts wear out.



### Safety Valve and De-pressurizing Tank

Each ProFoam 192 has a built in Safety Valve to protect from over pressurization. Disconnect the yellow air line from the compressor and use this valve to de-pressurize your system between fills and jobs. We recommend covering the valve with a rag each time you release the pressure.

## Component Overview

### PROTOCOL FOR FIRST TIME USE

Assemble your **ProFoam 192 System** in a non-contaminated environment using all the various tools and hose attachments. Use ProFoam Platinum and water only mixture for the first operational trial, whether operating with hand pump or compressor. Familiarity with the equipment's output and operation is one of the best training methods.

#### **The ProFoam 192 Advantage**

Unlike any other system on the market the ProFoam 192 allows the Technician to remove the ProFoam 192 Applicator Tank from the cart at any time and become completely mobile.

"I can remove the ProFoam 192 Tank from the Mobile Cart and then use it as a Hand Pump Foaming System at anytime." This capability has been one of the most repeated production advantages mentioned by the technicians.

Hand pumping the ProFoam 192 allows technicians to quickly treat many small areas of the job without having to move the complete ProFoam 192 Power Cart System.



- 1. Release the air supply line...**
- 2. Disconnect the velcro strap...**
- 3. You're ready to go!!**



**Once you become familiar with the components, setup takes less then 3 minutes.**



## System Contents

- ProFoam 192 1.5 Gallon Tank Dry Foam, Wet Foam and Liquid Outputs
- Power Cart Telescoping Handle with 120 Volt Compressor
- Trigger Gun c/w 60 Inch Connection Hose & Brass Quick Disconnect
- 39 to 20 Inch Adjustable Extension Wand
- 3 Foam Tips, High Volume .25 Nylon, Stainless Steel .125 Flex Injection Tip, Fan Spray Tip
- 2 Liquid Tips, Pin and Cone, Fan Spray and Screen & Check Valve Filter
- 8 Foot Foam Output Extension Hose
- 1 Drain Plate: 5 Inch Aluminum Plate



Foam and Liquid Tips



Foam Extension Hose



## Shipping Details

- Shipping Box 1 Dimensions: 10x10x24"
- Shipping Box 1 Weight: 9lbs
- Shipping Box 2 Dimensions: 16x13x14"
- Shipping Box 2 Weight: 19lbs



Trigger Gun



# Parts List

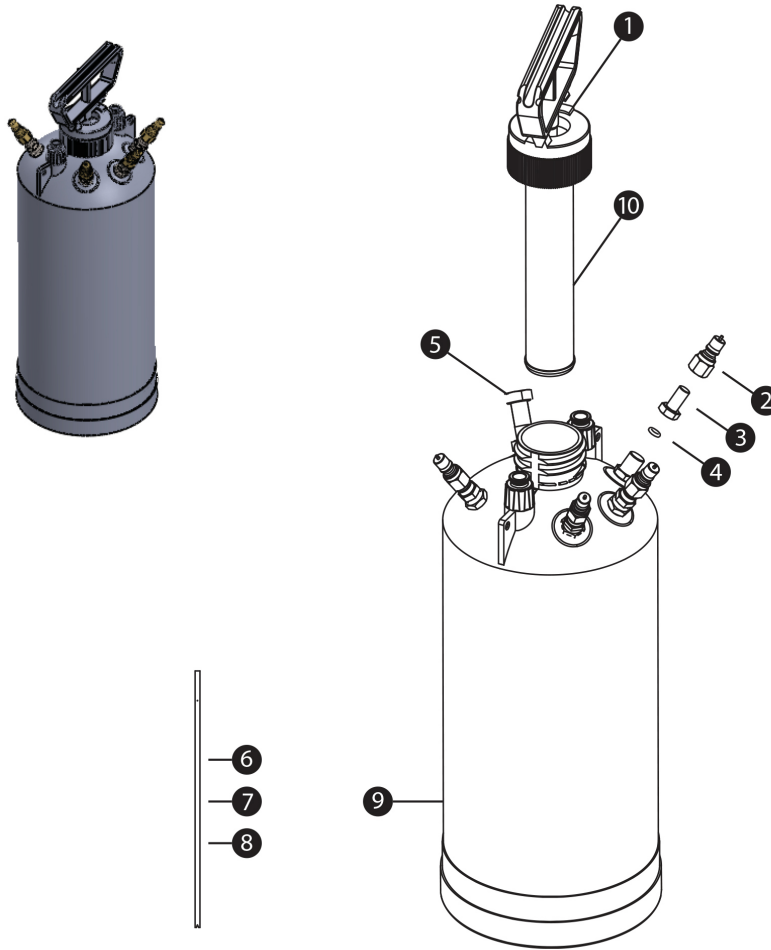

#	SKU	Description
1	<a href="#">PF-192-01</a>	Hand Pump Assembly
2	<a href="#">T-0061</a>	Male Plug Brass 1/8" FPT
3	<a href="#">M26666</a>	Bulk Head Assembly - Complete, 4 Pieces
3A	<a href="#">M26666A</a>	Safety Valve Bulk Head Assembly, 4 Pieces
4	<a href="#">2-112N900</a>	O Ring - Bulk Head Fittings
5	<a href="#">ST2512</a>	Safety Valve 55 PSI
6	<a href="#">5010-1.5</a>	Liquid Foam Output Tube
7	<a href="#">5008-1.5</a>	Wet Foam Output Tube
8	<a href="#">5009-1.5</a>	Dry Foam Output Tube
9	<a href="#">N2492P-192</a>	1.5 Gallon Replacement Tank - Complete
10	<a href="#">PF-192SK</a>	Hand Pump Seal Kit 3 Piece Set

# Parts List

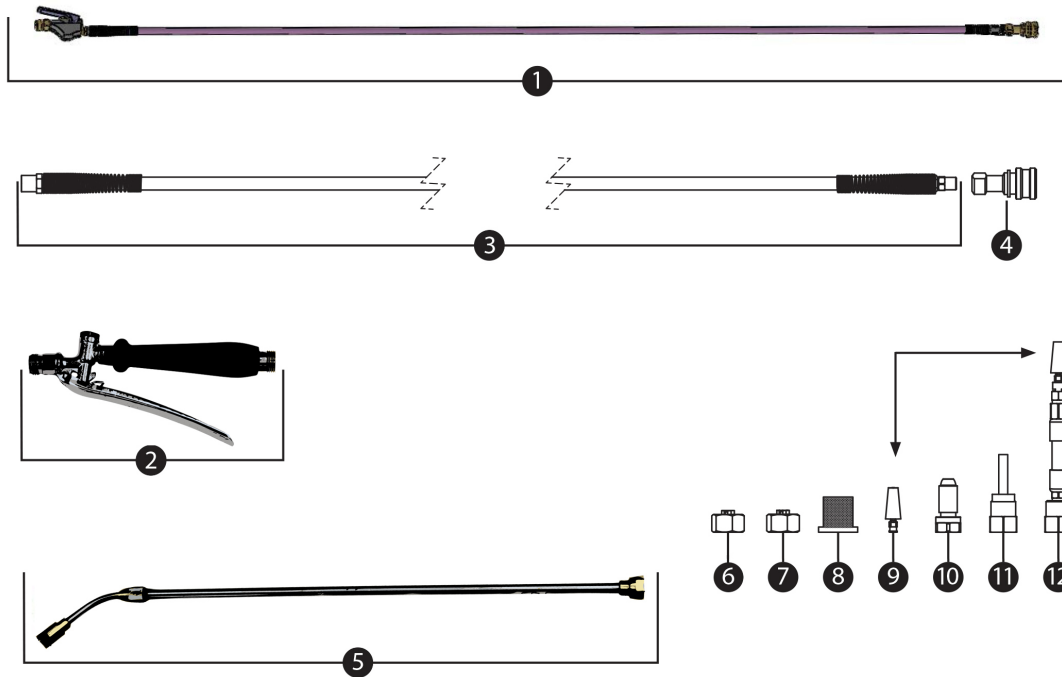



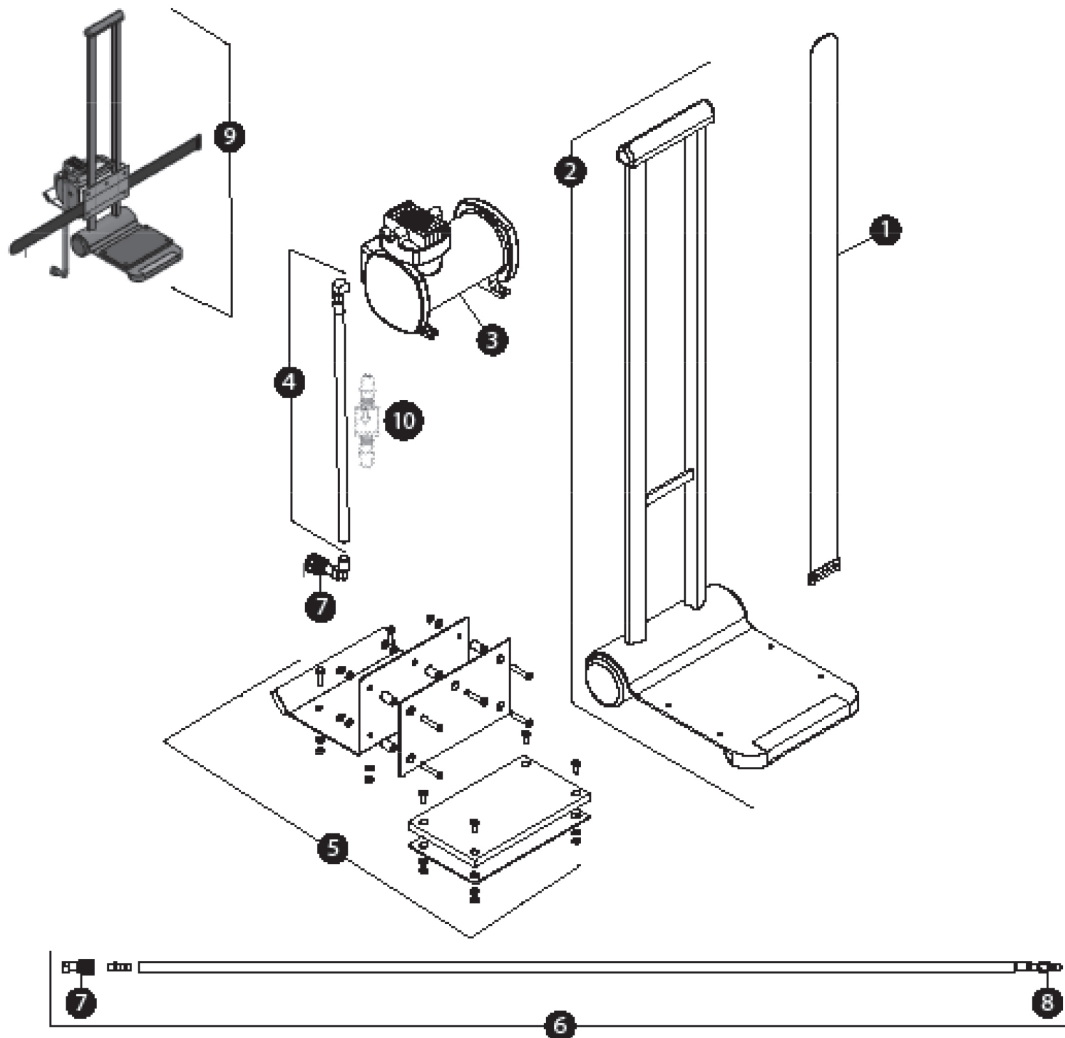

#	SKU	Description
1	<a href="#">PDS-6111-MTG-60</a>	Trigger Gun & Hose Valve Assembly Complete
2	<a href="#">PDS-6111-MTG</a>	Trigger Gun
3	<a href="#">PDS-60-60</a>	60 Inch Hose Assembly for Trigger Gun
4	<a href="#">T-0060</a>	Coupler Brass 1/8" MPT
5	<a href="#">PDS-046</a>	20" to 39" Extension Wand
6	<a href="#">T-8002</a>	Fan Spray Tip - Liquid
7	<a href="#">T-8008</a>	Fan Spray Tip - Foam
8	<a href="#">PDS-0094</a>	Screen Check Valve
9	<a href="#">NT-3/4SS-12</a>	Injection Tip + Rubber Cone
10	<a href="#">PDS-08</a>	Pin + Cone Liquid Spray Tip
11	<a href="#">NWF-2</a>	High Output Foam Tip
12	<a href="#">NWF-6</a>	Flexible Injection Tip - Foam

## Cart Parts List

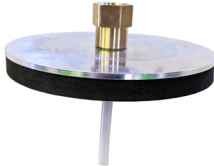

#	SKU	Description
1	<a href="#">BB-300</a>	Tank Mounting Strap
2	<a href="#">TR-100</a>	Mobile Cart Only
3	<a href="#">T-0050</a>	Compressor 120VAC Mobile
	<a href="#">T-0050-COM</a>	Compressor Complete 120VAC - Air Connection Hose, Brass Coupler Assembly For Mobile Cart
4	<a href="#">T-0051</a>	Air Output Tube Assembly
5	<a href="#">T-0010</a>	Aluminum Mounting Brackets
6	<a href="#">N2365</a>	8 Foot - 3/8 OD Extension Hose - Complete
7	<a href="#">T-0060</a>	Coupler - Brass 1/8" FPT
8	<a href="#">T-0061</a>	Plug - Brass Male 1/8" FPT
9	<a href="#">TR-2000</a>	Mobile Cart Complete Compressor, Brackets, Fittings

## Accessories List

SKU	Part Description	Ref. Images
<a href="#">N2365</a>	8 Foot - 3/8" OD Extension Hose Complete	 A coiled white braided extension hose with two brass fittings.
<a href="#">TT-111-25</a>	25 Foot Yellow Air Extension Hose	 A coiled yellow air extension hose with two brass fittings.
<a href="#">TT-48</a>	Drain Plate	 A circular drain plate with a brass fitting on top and a white tube extending from the bottom.
<a href="#">TT-105</a>	Sub Slab Injection Rod	 A long, thin metal injection rod with a brass fitting at the top and a small nozzle at the bottom.
<a href="#">TT-105A</a>	Sub Slab Quick Disconnect Adapter	 A brass quick disconnect adapter with a hexagonal base and a threaded top.



# **NPD EQUIPMENT**

---

## **PERSONAL SAFETY, OPERATION AND LIMITED WARRANTY INFORMATION**

### **PERSONEL SAFETY**

- 1. Use eye, face, breathing and ear protection as required. Always wear ANSI approved impact safety goggles, which must provide both frontal and side protection. Protect your hands with suitable gloves. Wear an ANSI approved dust mask or respirator. Wear ANSI approved earplugs.**
- 2. Do not over reach; keep proper footing and balance at all times. Proper footing and balance enables better control of the applicator in unexpected situations. Applicator must remain upright during all operations.**
- 3. Dress properly, wear protective equipment. Do not wear loose clothing or jewelry as they can be caught in moving parts. Tie back long hair. Protective, electrically non-conductive clothes and non-skid footwear are recommended when working.**
- 4. Stay alert, watch what you are doing and use your common sense. Do not operate any machine or tool when you are tired, under the influence of drugs, alcohol or medications.**
- 5. Use clamps or other practical ways to secure and support the equipment when in use. Holding the work piece by hand or against your body is unstable and may lead to loss of control and discharge. Avoid SERIOUS INJURY or PROPERTY DAMAGE from discharge of spray material.**
- 6. Do not allow spray to strike you and do not spray toward people or animals. Do not spray the tool itself or any electrical source.**

### **OPERATION**

- 1. Get familiar with your equipment applicator first by operating in a non contaminated environment; water only, this allows for basic understanding of operation and use of the various spray tips. Check for any leaks or malfunctioning parts.**
- 2. Applicator operates with liquid under pressure and should be observed at all times, DO NOT PRESSURIZE applicator if tank, hose or other parts appear to be damaged or loose.**
- 3. Read and understand all chemical manufacturers label instructions before filling or using this equipment. Follow their regulations, some chemicals are restricted.**

4. **DO NOT USE ANY FLAMMABLES OR BOILING LIQUIDS IN THIS SPRAYER** as it is not designed nor intended for such use.

5. **INSPECT** both inside and outside of the sprayer as a daily routine, clean as required to ensure all devices are functioning correctly.

6. Each applicator is equipped with a Pressure Release Valve, ensure your applicator is in a safe place before refilling. Depressurize applicator by turning the Hand Pump slightly until you hear air escaping, stop and allow the air to discharge. Remove Hand Pump Cylinder only when the pressure is removed.

7. **DO NOT OVERFILL** passed 1 1/2 G. the Max Fill line. Air space in top portion of tank must be maintained at all times for proper operation.

8. The Pressure Release Valve is a safety feature and designed to open when system is not operated correctly. Applicator **MUST** remain upright and not overfilled to operate correctly.

9. The applicator contains seals and gaskets that will require replacement. Operator needs to inspect these areas during a daily inspection and cleaning program.

10. Store you applicator depressurized and safe place. Keep out of reach from children and pets.

11. Call our service department at 877-734-0932 for further details. Other accessories and parts are available for various spraying methods.

## **LIMITED WARRANTY**

**1. DURATION:** From the date of purchase by the original purchaser as follows: Manufacturer defects 3 months, No warranty on battery or seals.

**2. WHO GIVES THIS WARRANTY (WARRANTOR):** NPD (NPD Products Ltd.) 2325 Old Second South Midhurst, Ontario, Canada L9X 1P3 705-734-0932

**3. WHO RECEIVES THIS WARRANTY (PURCHASER):** The original purchaser (other than for purposes of resale) of the NPD product.

**4. WHAT PRODUCTS ARE COVERED BY THIS WARRANTY:** Any NPD product, accessory supplied or manufactured by Warrantor.

**5. WHAT IS COVERED UNDER THIS WARRANTY:** Substantial defects in material and workmanship which occur within the duration of the warranty period. Battery and seals excluded.

## **6. WHAT IS NOT COVERED UNDER THIS WARRANTY:**

A. Implied warranties, including those of merchantability and FITNESS FOR A PARTICULAR PURPOSE ARE LIMITED FROM THE DATE OF ORIGINAL PURCHASE AS STATED IN THE DURATION. Some States do not allow limitation on how long the implied warranty lasts, so the above limitation or exclusion may not apply to you.

B. ANY INCIDENTAL, INDIRECT, OR CONSEQUENTIAL LOSS, DAMAGE, OR EXPENSE THAT MAY RESULT FROM ANY DEFECT, FAILURE, OR MALFUNCTION OF THE NPD PRODUCT. Some States do not allow exclusion or limitation of incidental or consequential damages, so the above limitation or exclusion may not apply to you.

C. Any failure that results from an accident, purchaser's abuse, neglect or failure to operate products in accordance with instructions provided in the owner's manual(s) supplied with product. Accident, purchaser's abuse, neglect or failure to operate products in accordance with instructions shall also include the removal or alteration of any devices, if such safety devices are removed or altered, this warranty is VOID.

D. Normal adjustments which are explained in the owner's manual(s) provided with this product.

### **RESPONSIBILITIES OF WARRANTOR UNDER THIS WARRANTY:**

Repair or replace at Warrantor's option, products or components which are defective, have malfunctioned and/or failed to conform within duration of the warranty period.

## **7. RESPONSIBILITIES OF PURCHASER UNDER THIS WARRANTY:**

A. Provide dated proof of purchase and maintenance records.

B. Deliver or ship the NPD products to the address above. Freight costs, if any, must be borne by the purchaser.

C. Use reasonable care in the operation and maintenance of the products as described in the owner's manual(s)

## **8. WHEN WARRANTOR WILL PERFORM REPAIR OR REPLACEMENT UNDER THIS WARRANTY:**

A. Repair or replacement will be scheduled and services according to the normal work flow at the servicing location, and depending on the availability of replacement parts. This Limited Warranty applied in the US and Canada only and gives you specific legal rights. You may also have other rights which vary from state to state or country to country.

## **IMPORTANT SAFETY PERCAUTIONS**

**WARNING!** Read and understand all chemical manufacturers label instructions before using this equipment.

Failure to follow all instructions may result in electric shock, fire and /or personal injury. Keep this information for the safety warnings and percautions, operating, inspection and maintenance instructions. When using this equipment, basic percautions should always be followed to reduce the risk of personal injury and/or damage to the equipment. Note that when this manual refers to a part number, it refers to the parts list included.